



■ Features :

- Constant voltage mode power supply
- Universal AC input / Full range
- Protections: Short circuit / Over current / Over voltage
- Fully isolated plastic case
- Cooling by free air convection
- Small and compact size
- Pass LPS
- 100% full load burn-in test
- Low cost, high reliability
- Suitable for LED lighting and moving sign applications
- 2 years warranty

SPECIFICATION

LPS

MODEL	APV-16-5	APV-16-12	APV-16-15	APV-16-24	
OUTPUT	DC VOLTAGE	5V	12V	15V	24V
	RATED CURRENT	2.6A	1.25A	1A	0.67A
	CURRENT RANGE	0 ~ 2.6A	0 ~ 1.25A	0 ~ 1A	0 ~ 0.67A
	RATED POWER	13W	15W	15W	16.08W
	RIPPLE & NOISE (max.) Note.2	100mVp-p	120mVp-p	120mVp-p	150mVp-p
	VOLTAGE TOLERANCE Note.3	±5.0%			
	LINE REGULATION	±1.0%			
	LOAD REGULATION	±2.0%			
SETUP, RISE TIME Note.6	1500ms, 30ms / 230VAC		1500ms, 30ms / 115VAC at full load		
HOLD UP TIME (Typ.)	20ms/230VAC	12ms/115VAC at full load			
INPUT	VOLTAGE RANGE Note.4	90 ~ 264VAC	127 ~ 370VDC		
	FREQUENCY RANGE	47 ~ 63Hz			
	EFFICIENCY (Typ.)	76%	79%	80%	82%
	AC CURRENT	0.3A/230VAC 0.5A/115VAC			
	INRUSH CURRENT(max.)	COLD START 35A/115VAC		70A/230VAC	
LEAKAGE CURRENT	0.25mA / 240VAC				
PROTECTION	OVER CURRENT	Above 105% rated output power Protection type : Hiccup mode, recovers automatically after fault condition is removed			
	OVER VOLTAGE	5.75 ~ 6.75V	13.8 ~ 16V	17.5 ~ 21V	28 ~ 32V
ENVIRONMENT	WORKING TEMP.	-30 ~ +70°C (Refer to output load derating curve)			
	WORKING HUMIDITY	20 ~ 90% RH non-condensing			
	STORAGE TEMP., HUMIDITY	-40 ~ +80°C, 10 ~ 95% RH			
	TEMP. COEFFICIENT	±0.03%/°C (0 ~ 50°C)			
	VIBRATION	10 ~ 500Hz, 2G 10min./1cycle, period for 60min. each along X, Y, Z axes			
SAFETY & EMC	SAFETY STANDARDS	Design refer to TUV EN60950-1, EN61347-2-13, UL8750			
	WITHSTAND VOLTAGE	I/P-O/P:3KVAC			
	ISOLATION RESISTANCE	I/P-O/P:>100M Ohms / 500VDC / 25°C / 70% RH			
	EMI CONDUCTION & RADIATION	Compliance to EN55022 (CISPR22) Class B, EN55015, EN61547			
	HARMONIC CURRENT	Compliance to EN61000-3-2 Class A, EN61000-3-3			
EMS IMMUNITY	Compliance to EN61000-4-2, 3, 4, 5, 6, 8, 11; ENV50204, EN55024, light industry level (surge 2KV), criteria A				
OTHERS	MTBF	Khrs min. MIL-HDBK-217F (25°C)			
	DIMENSION	77*40*29mm (L*W*H)			
	PACKING	Kg; pcs/ Kg/ CUFT			
NOTE	<ol style="list-style-type: none"> 1. All parameters NOT specially mentioned are measured at 230VAC input, rated load and 25°C of ambient temperature. 2. Ripple & noise are measured at 20MHz of bandwidth by using a 12" twisted pair-wire terminated with a 0.1uf & 47uf parallel capacitor. 3. Tolerance : includes set up tolerance, line regulation and load regulation. 4. Derating may be needed under low input voltage. Please check the static characteristics for more details. 5. The power supply is considered as a component that will be operated in combination with final equipment. Since EMC performance will be affected by the complete installation, the final equipment manufacturers must re-qualify EMC Directive on the complete installation again. 6. Length of set up time is measured at first cold start. Turning ON/OFF the power supply may lead to increase of the set up time. 				

Mechanical Specification

Unit:mm

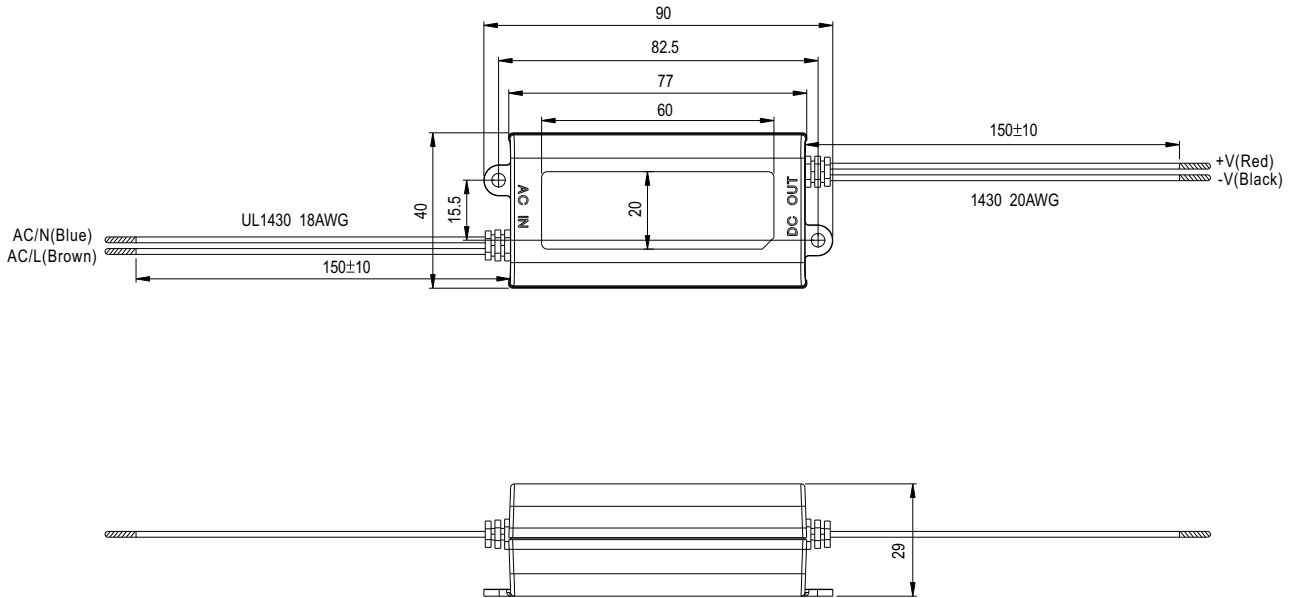

Block Diagram

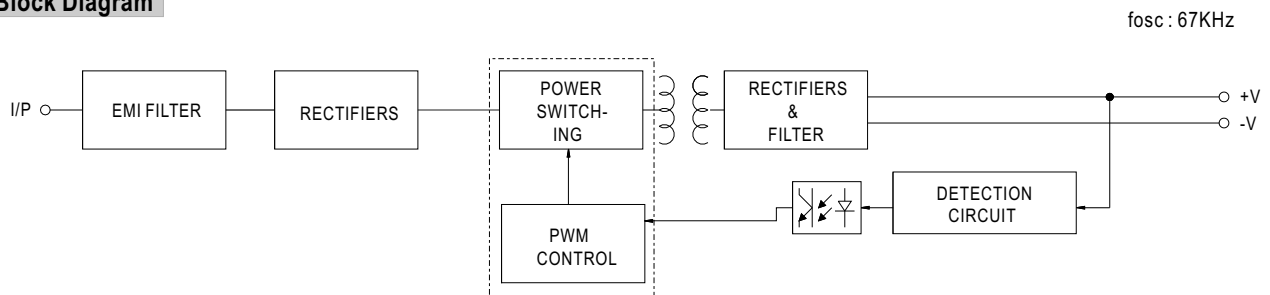

Derating Curve

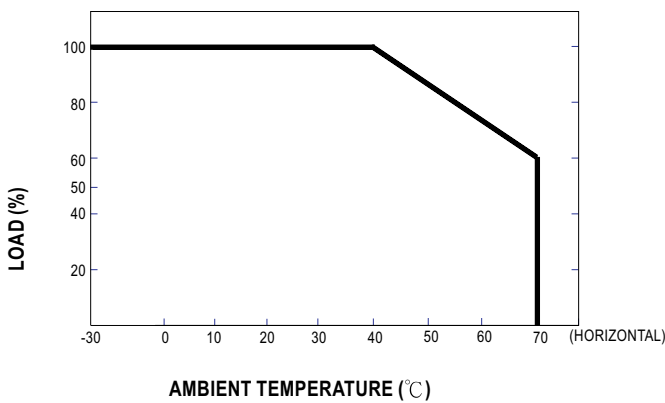

Static Characteristics

