



■ Features :

- Protections: Short circuit / Overload / Over voltage / Over temperature
- 2000VAC I/O Isolation
- Forced air cooling by built-in DC fan with fan speed control
- High power density 10.7w/inch<sup>3</sup>
- 1U low profile 41mm
- SD-1000L type input voltage design refer to LVD
- Output OK Signal
- Built-in remote ON-OFF control
- Built-in remote sense function
- 3 years warranty



**SPECIFICATION**

MODEL	SD-1000L-12	SD-1000L-24	SD-1000L-48	SD-1000H-12	SD-1000H-24	SD-1000H-48	
OUTPUT	DC VOLTAGE	12V	24V	48V	12V	24V	48V
	RATED CURRENT	60A	40A	21A	60A	40A	21A
	CURRENT RANGE	0 ~ 60A	0 ~ 40A	0 ~ 21A	0 ~ 60A	0 ~ 40A	0 ~ 21A
	RATED POWER	720W	960W	1008W	720W	960W	1008W
	RIPPLE & NOISE (max.) Note.2	150mVp-p	150mVp-p	150mVp-p	150mVp-p	150mVp-p	150mVp-p
	VOLTAGE ADJ. RANGE	11 ~ 15V	23 ~ 30V	46 ~ 60V	11 ~ 15V	23 ~ 30V	46 ~ 60V
	VOLTAGE TOLERANCE Note.3	±1.0%	±1.0%	±1.0%	±1.0%	±1.0%	±1.0%
	LINE REGULATION	±0.5%	±0.5%	±0.5%	±0.5%	±0.5%	±0.5%
	LOAD REGULATION	±0.5%	±0.5%	±0.5%	±0.5%	±0.5%	±0.5%
SETUP, RISE TIME	500ms, 50ms at full load						
INPUT	VOLTAGE RANGE Note.5	19 ~ 72VDC			72 ~ 144VDC		
	EFFICIENCY (Typ.)	84%	88%	90%	85%	89%	91%
	DC CURRENT (Typ.)	23.5A/48VDC			11.6A/96VDC		
	INRUSH CURRENT (Typ.)	-----			100A/96VDC		
PROTECTION	OVERLOAD	105 ~ 125% rated output power Protection type : Constant current limiting, unit will shut down o/p voltage about 5sec. Re-power on to recover					
	OVER VOLTAGE	16 ~ 19V	30.8 ~ 35.2V	62 ~ 68V	16 ~ 19V	30.8 ~ 35.2V	62 ~ 68V
	OVER TEMPERATURE	85°C ±5°C (TSW2) detect on heatsink of O/P diode; 75°C ±5°C (TSW1) detect on heatsink of power transistor Protection type : Shut down o/p voltage, recovers automatically after temperature goes down					
FUNCTION	REMOTE ON/OFF CONTROL	Please refer to function manual					
	OUTPUT OK SIGNAL	Open collector signal low when PSU turns on, Max. sink current : 10mA					
ENVIRONMENT	WORKING TEMP.	-20 ~ +60°C (Refer to output load derating curve)					
	WORKING HUMIDITY	20 ~ 90% RH non-condensing					
	STORAGE TEMP., HUMIDITY	-40 ~ +85°C, 10 ~ 95% RH					
	TEMP. COEFFICIENT	±0.02%/°C (0 ~ 50°C)					
	VIBRATION	10 ~ 500Hz, 2G 10min./1cycle, 60min. each along X, Y, Z axes					
SAFETY & EMC (Note 4)	SAFETY STANDARDS	IEC60950-1 CB approved by TUV					
	WITHSTAND VOLTAGE	I/P-O/P:2KVAC I/P-FG:1.5KVAC O/P-FG:0.5KVAC					
	ISOLATION RESISTANCE	I/P-O/P, I/P-FG, O/P-FG:100M Ohms/500VDC 25°C 70%RH					
	EMI CONDUCTION & RADIATION	Compliance to EN55022 (CISPR22)					
	EMS IMMUNITY	Compliance to EN61000-4-2,3,4,6,8; ENV50204, light industry level, criteria A					
OTHERS	MTBF	32K hrs min. MIL-HDBK-217F (25°C)					
	DIMENSION	295*127*41mm (L*W*H)					
	PACKING	1.94Kg; 6pcs/12.6Kg/0.99CUFT					
NOTE	<ol style="list-style-type: none"> <li>1. All parameters NOT specially mentioned are measured at 48,96VDC input, rated load and 25°C of ambient temperature.</li> <li>2. Ripple &amp; noise are measured at 20MHz of bandwidth by using a 12" twisted pair-wire terminated with a 0.1uf &amp; 47uf parallel capacitor.</li> <li>3. Tolerance : includes set up tolerance, line regulation and load regulation.</li> <li>4. The power supply is considered a component which will be installed into a final equipment. The final equipment must be re-confirmed that it still meets EMC directives.</li> <li>5. Derating may be needed under low input voltages. Please check the derating curve for more details.</li> </ol>						

**Mechanical Specification**

Case No. 952B Unit:mm

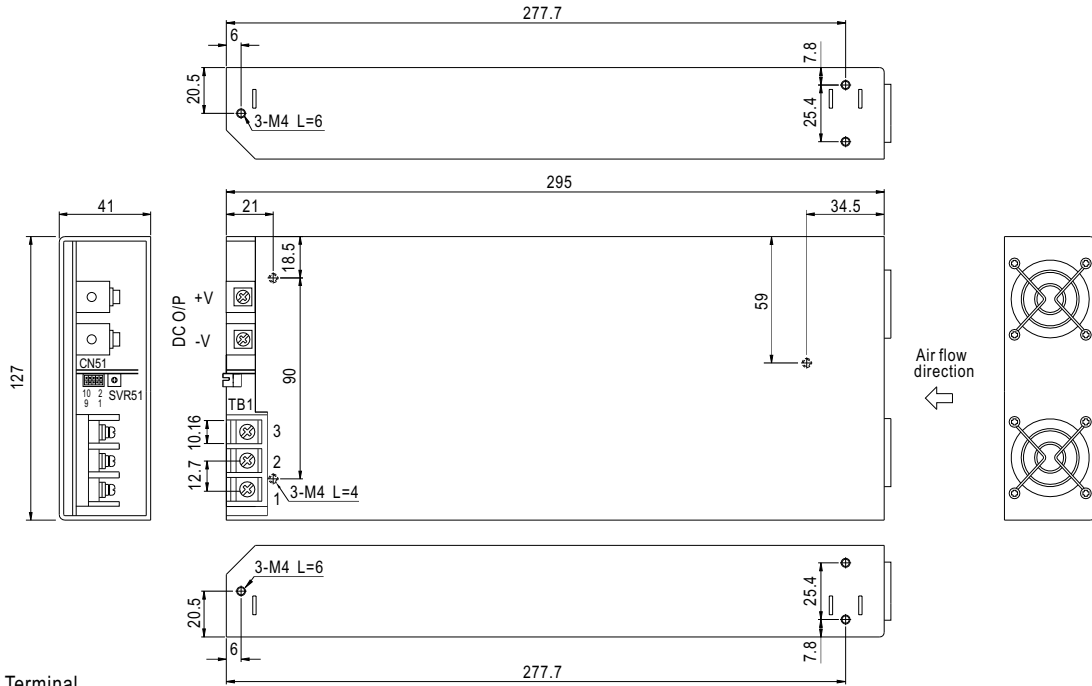

DC Input Terminal  
Pin No. Assignment

Pin No.	Assignment
1	DC INPUT V+
2	DC INPUT V-
3	FG $\perp$

Control pin number assignment (CN51) : JST B10B-PHDSS or equivalent

Pin No.	Assignment	Pin No.	Assignment	Pin No.	Assignment	Mating Housing	Terminal
1	+S	5	AUX	9	RCG	JST PHDR-10VS or equivalent	JST SPHD-002T-P0.5 or equivalent
2	-S	6	AUXG	10	NC		
3	OUTPUT OK	7	RC1				
4	GND	8	RC2				

**Block Diagram**

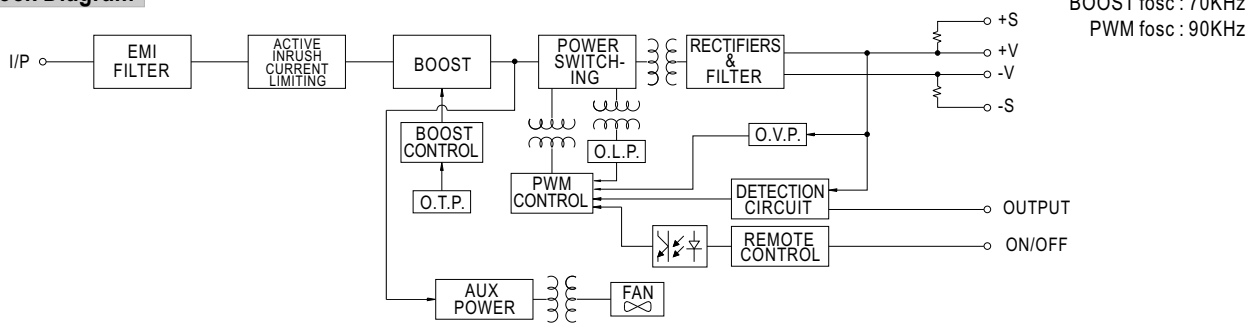

BOOST fosc : 70KHz  
PWM fosc : 90KHz

**Derating Curve**

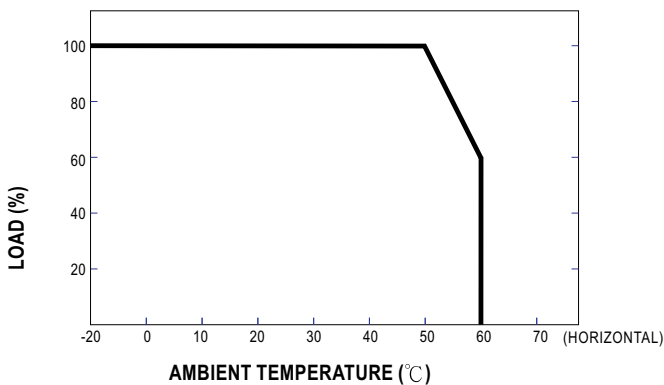

**Static Characteristics**

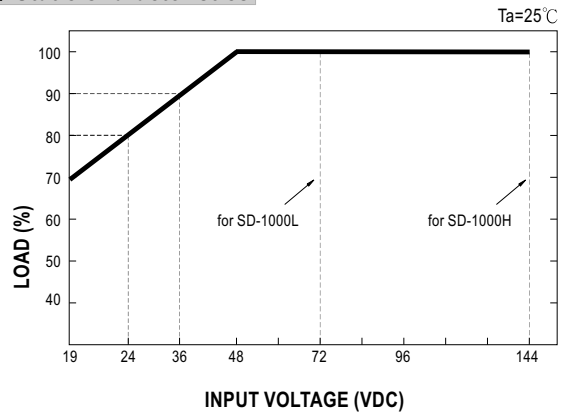

■ **Function Description of CN51**

Pin No.	Function	Description
1	+S	Positive sensing. The +S signal should be connected to the positive terminal of the load. The +S and -S leads should be twisted in pair to minimize noise pick-up effect. The maximum line drop compensation is 0.5V.
2	-S	Negative sensing. The -S signal should be connected to the negative terminal of the load. The -S and +S leads should be twisted in pair to minimize noise pick-up effect. The maximum line drop compensation is 0.5V.
3	O/P OK	Open collector signal, referenced to pin4(GND). Low when PSU turns on. The maximum sink current is 10mA and the maximum external voltage is 13V.
4	GND	These pins connect to the negative terminal (-V).
5	AUX	Auxiliary voltage output, 10.8~13.2V referenced to pin6(AUXG).The maximum load current is 0.25A.
6	AUXG	Auxiliary voltage output ground. The signal return is isolated from the output terminals(+V & -V).
7	RC1	Remote ON/OFF
8	RC2	Remote ON/OFF
9	RCG	Remote ON/OFF ground
10	NC	No connection

■ **Function Manual**

**1.Remote ON/OFF**

- (1)Remote ON/OFF control becomes available by applying voltage in CN51
- (2)Table 1.1 shows the specification of Remote ON/OFF function
- (3)Fig.1.2 shows the example to connect Remote ON/OFF control function

Table 1.1 Specification of Remote ON/OFF

Connection Method	Fig. 1.2(A)	Fig. 1.2(B)	Fig. 1.2(C)
SW Logic	Output on	SW Open	SW Close
	Output off	SW Close	SW Open

Fig.1.2 Examples of connecting remote ON/OFF

(A)Using external voltage source

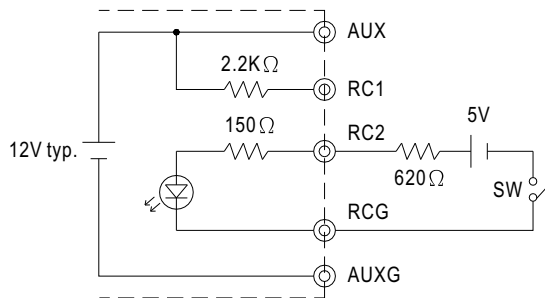

(B)Using internal 12V auxiliary output

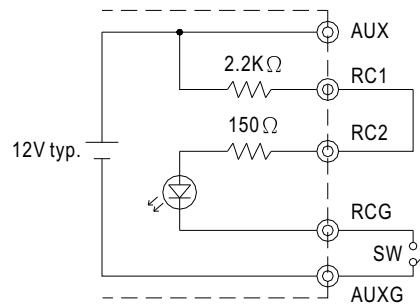

(C)Using internal 12V auxiliary output

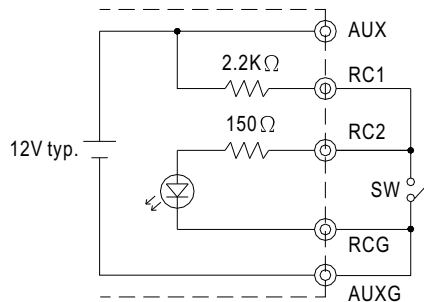

**2. Output OK signal**

"Output OK" is an open collector signal. It indicates the output status of the PSU. It can operate in two ways : One is sinking current from external signal ; the other is sending out a voltage signal.

**2-1 Sink current :**

The maximum sink current is 10mA and the maximum external voltage is 13V.

**2-2 Voltage signal :**

Between O/P OK(pin3) and GND(pin4)	Output Status
0 ~ 0.5V	ON
12 ~ 13V	OFF

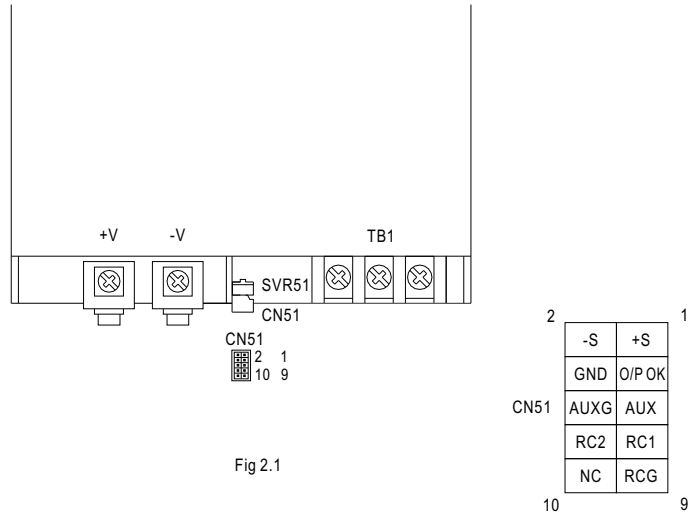

Fig 2.1

**3. Remote Sense**

The remote sensing compensates voltage drop on the load wiring up to 0.5V.

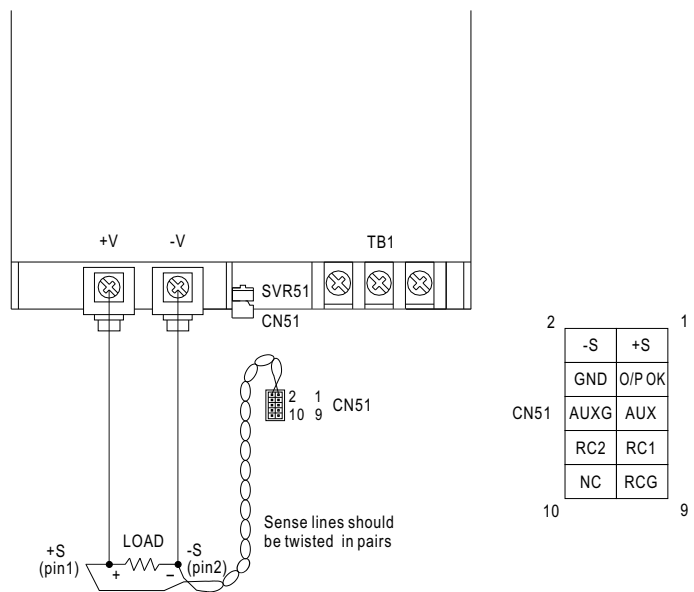

Fig 3.1